

NexGen[®] CR-Flex and LPS-Flex Knees

Design Rationale



Table of Contents

Introduction	2
High Flexion in Activities of Daily Living	3
Key Elements in Achieving Deep Flexion	4
Patient Factors	
Surgical Factors	
Rehabilitation Regimen	
Implant Design	
Key Aspects of NexGen Flex Fixed Bearing Knees	7
Component Design—Addressing the Issues that Influence Deep Flexion	
Contact Area and Conformity	
Stress on the Extensor Mechanism	
Balancing Flexion and Extension Gaps	
Patellofemoral Design	
Cruciate Retaining	
Posterior Stabilized	
Fixation	16
Instrumentation	17
Flex Cut	17
Testing and Analysis	18
NexGen Flex Knee Testing Anterior Lift-Off Testing	
Contact Area and Conformity	19
Secondary Locking Mechanism	21
NexGen CR-Flex Testing	21
Posterior Edge Loading	
Femoral Component Strength Analysis	
Patellofemoral Joint Compression Analysis	23
NexGen LPS-Flex Testing	25
Bearing Spine Testing	
Posterior Lift-Off Testing	
References	27

Introduction

Only a few studies have been published regarding the normal range of joint motion, and most of these are from the western hemisphere.^{1,2,3} As the reach of our designs becomes more global, we know that there are many other cultural activities and lifestyles that require considerably more squatting and kneeling activities in everyday life. Normal range of motion for the average Asian or Middle Eastern person performing such cultural and religious activities is considered to be between 130 and 155 degrees.^{2,4} Patient-related factors such as physical condition, age, and activity type and level differ greatly across populations and cultures. These can play a direct role in determining the range of motion that can be achieved after TKA surgery.

Regardless of culture and background, the process of getting in and out of a kneeling position can be aided by high flexion capability.

High Flexion in Activities of Daily Living

As progress and experience with total knee arthroplasty (TKA) has accrued over the years, the procedure has achieved better functional results and brought greater satisfaction to patients.⁵ The average passive flexion for patients who have undergone TKA is 110 to 115 degrees.⁶ While this is adequate for some TKA patients, many patients today are younger and more active. Typical patients are now more likely to have the need, desire, and ability to achieve a greater range of motion so they can resume their lifestyles after total knee replacement. They do not want to give up the cultural, religious, recreational, or work activities they have enjoyed throughout their lives.

Preoperatively, some patients may be able to achieve a range of motion as high as 130 to 155 degrees. Although it may be possible to attain these high flexion angles postoperatively with traditional total knee prostheses, these implants are not designed to safely accommodate such high flexion. As these implants move into higher flexion angles, the contact area between the posterior femoral condyles and the tibial bearing is reduced. This reduction in contact area increases contact stress, which may increase the potential for polyethylene damage. Also, high flexion may be somewhat limited by impingement of the inferior patella bone on the front of the tibial bearing.

Prosthetic designs that safely accommodate deep flexion are becoming increasingly important. This design rationale examines the patient factors, surgical techniques, rehabilitation regimen, and prosthetic designs that contribute to successful TKA in patients with the ability and desire to perform high-flexion activities. It also explains some of the key features of the NexGen® CR-Flex and NexGen Legacy® LPS-Flex Fixed Bearing Knees.

The CR-Flex and LPS-Flex Fixed Bearing Knees represent enhancements of the highly successful NexGen CR and NexGen Legacy LPS Knees. Both CR-Flex and LPS-Flex knees are designed to safely accommodate flexion of up to 155 degrees. Moreover as postoperative flexion can be somewhat unpredictable, the CR-Flex and LPS-Flex knees have been designed for use in all patients, including those who do not appear to have the need to achieve higher flexion.

Key Elements in Achieving Deep Flexion

Factors influencing range of motion after total knee arthroplasty are multiple. The results from many studies investigating factors influencing postoperative range of motion can be grouped into the following four areas—patient, surgical, rehabilitation regime, and implant design.

Patient Factors

The results of studies investigating postoperative range of motion show that many factors are involved relative to the age, physical condition, and activity level of the patient. In particular, these studies demonstrate that preoperative range of motion and the degree of flexion contracture influence postoperative range of motion.^{1,2,5} According to one study there was evidence of an association between the preoperative flexion score and the change in flexion after arthroplasty for both osteoarthritis and rheumatoid arthritis.³ Based on some of these studies, it appears that total knee arthroplasty patients with good preoperative flexion will have a greater likelihood of maintaining or improving their flexion after total knee arthroplasty.

Our NexGen Knee outcomes study, (Figures 1, 2), which now spans more than seven years, has compiled demographic and operative surgical information from both U.S. and European centers.

The frequency distribution of preoperative flexion was reported for 12,481 primary TKA cases participating in the U.S. clinical outcomes study of the NexGen Knee System. Flexion was measured in increments of 10 degrees, and the data are presented in Figure 1 below. Cases with preoperative flexion reported to be greater than 140 degrees were excluded prior to summarization. Results presented in Figure 1 indicate that preoperative knee flexion of 125 degrees or more is fairly common (30% of primary TKA cases in the U.S.).

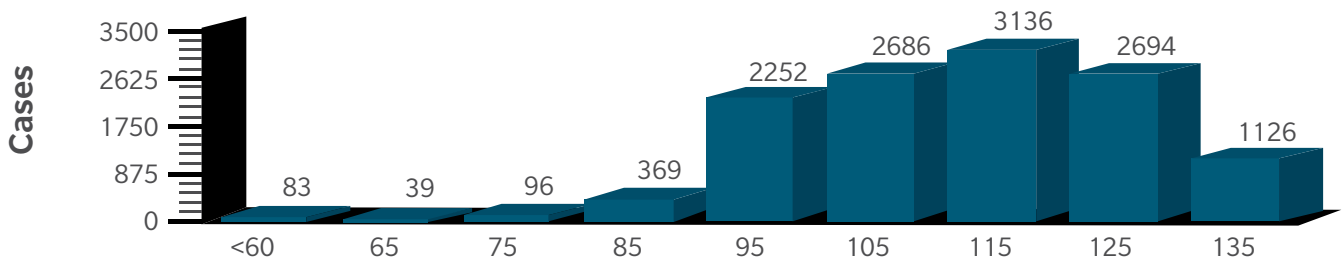

Figure 1
Distribution of Preoperative Flexion in U.S. TKA Cases (Data on file at Zimmer Biomet)

The frequency distribution of preoperative flexion was reported for 11,912 primary TKA cases participating in the global (excluding U.S.) clinical outcomes study of the NexGen Knee System. Flexion was measured in increments of 10 degrees, and the data are presented in Figure 2 below. Results presented in Figure 2 indicate that preoperative knee flexion of 125 degrees or more is also fairly common (34% of primary TKA cases in the global group).

High flexion, however, is not ensured for any patient. There are specific, common patient characteristics that may preclude high-flexion activities, even when using a prosthesis designed to accommodate high flexion. Usually, these characteristics are present preoperatively. For example, patients with excessive fatty tissue in the thigh and calf are typically unable to achieve high flexion because the tissue mass prevents deep flexion.

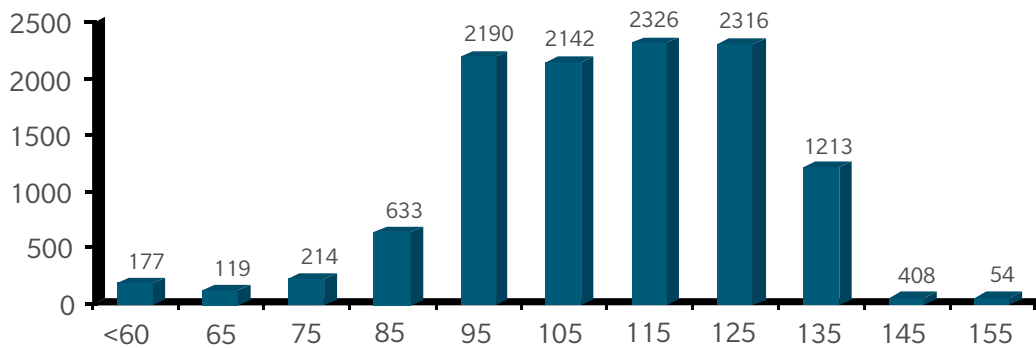

Figure 2

Distribution of Preoperative Flexion in Global TKA Cases Excluding United States (data on file at Zimmer Biomet)

Surgical Factors

Surgery-related factors that influence postoperative range of motion include balancing the flexion and extension gaps, removing posterior osteophytes, and restoring the joint line. Postoperative rehabilitation is also an important consideration.

Proper balancing of the flexion and extension gaps will help maximize stability as the patient performs high-flexion activities. The femoral component should be aligned with respect to the epicondylar axis to avoid condylar lift-off and help ensure the best condition for safe, high range of motion.⁷ Balancing the flexion and extension gaps can be facilitated by providing a variety of sizing options with the ability to vary the outer A/P dimension of the femoral component independent of the box cut dimension (CR-Flex) and the offering of multiple bearing thicknesses.

Failure to remove posterior femoral osteophytes may result in bony impingement on the implant during high-flexion activities. Osteophytes may also “tent” the soft tissue structures, further limiting range of motion. Release of the posterior capsule is often necessary to allow adequate access to posterior osteophytes.

Close attention must be paid to maintaining the joint line. Depending on the degree, altering the joint line can adversely affect patellar tracking and limit the range of motion. An elevated joint line, for example, can cause tibiofemoral tightness during rollback and thus restrict flexion.

Rehabilitation Regimen

Another important factor to gain and maintain high flexion after successful total knee arthroplasty is rehabilitation. For those patients undergoing TKA who are able and willing to bend more deeply and wish to maintain preoperative flexibility, many surgeons recommend early and aggressive rehabilitation. For more information on the details of these protocols, please contact your local Zimmer Biomet representative.

Implant Design

Most traditional TKA implants were designed to accommodate flexion up to approximately 125 degrees. While greater flexion angles are possible with these implants, the biomechanical design of the implants is not optimized for higher flexion. These design issues are addressed in the design of the NexGen CR-Flex and NexGen Legacy LPS-Flex Fixed Bearing Knee Implants. Some of these issues are common to both cruciate retaining and posterior stabilized designs. The common issues relate to contact area between the femoral component condyles and the tibial bearing during deep flexion, stresses on the extensor mechanism during deep flexion, patellar tracking, sizing to facilitate balancing of the flexion and extension gaps, and anterior lift-off of the tibial bearing. Other implant-related issues are specific to either the cruciate retaining or posterior stabilized design.

Several design factors can be incorporated into TKA components that allow a TKA patient to achieve high flexion safely. The femoral component can be designed with extended radii on the posterior condyles; a deepened patellar groove; and a broad, conforming surface for stability in full extension.⁸ The tibial bearing can be modified by removing material on the anterior face to provide clearance for the patella and patellar tendon during high flexion. Other design factors, including those specific to either the cruciate retaining or posterior stabilized design, can also be included. These design elements and their related issues are discussed in more detail in the following sections.

Key Aspects of The Nexgen Flex Fixed Bearing Knees

The NexGen CR-Flex and NexGen Legacy LPS-Flex Fixed Bearing Knees are designed to safely accommodate high flexion. The design allows a maximum active (under load) flexion of 155 degrees and a passive (no load) flexion of 165 degrees. Specific design features help maintain tibiofemoral contact during high flexion, balance flexion and extension gaps, and minimize tension on the quadriceps mechanism by providing greater clearance for the patellar tendon.

Key features of the NexGen Flex Fixed Bearing Knee Components include:

- **Extended Posterior Femoral Condyles** to increase contact area in deep flexion; and
- **Deeper Anterior Cutout** on the tibial bearing to reduce patellar tendon tension and provide relief for the inferior patellar bone

Key features specific to the NexGen CR-Flex Fixed Bearing Knee include:

- **Minus Sizes** that are 2 mm smaller in the external A/P dimension to provide an additional means of adjusting the flexion gap without affecting the extension gap. (CR-Flex only);
- **Enhanced Lateral** condyle to further aid asymmetric femoral rollback;
- **Wider Intercondylar Opening** to promote internal/external rotation during high flexion and provide more space for the PCL;
- **Lowered Height** of lateral condyle to reduce the tightness of the lateral retinacular ligament during high flexion; and
- **Narrower M/L Width** to allow the surgeon greater flexibility to adjust the mediolateral position of the femoral component.

Key features specific to the NexGen LPS-Flex Fixed Bearing Knee include:

- **Increased (or enhanced)** resistance to anterior subluxation.

Although the systems are designed to accommodate high flexion, their use is not limited to patients seeking to perform high-flexion activities. The CR-Flex and LPS-Flex knees are appropriate for any patient who would otherwise satisfy the indications for a cruciate retaining or posterior stabilized implant design.

The geometry of the NexGen CR-Flex and LPS-Flex Prostheses are adaptations of the NexGen CR and LPS Knees, which now have more than seven years of successful clinical experience.⁴ Furthermore, they use the same instrumentation as the standard NexGen CR and LPS Prostheses. Interchangeability among the components allows the surgeon to switch from the cruciate retaining design to the posterior stabilized design intraoperatively. Also, interchangeability is possible between the standard and flex components as long as the posterior condyle flex cut has not yet been made.

Component Design— Addressing the Issues that Influence Deep Flexion

To safely achieve high flexion, it is important for the design of the knee prosthesis to be “high-flexion friendly.” It must contain specific design elements that allow the prosthesis to accommodate high flexion while avoiding characteristics that limit the opportunity for high flexion. With these parameters in mind, the NexGen CR and NexGen Legacy LPS Knees were redesigned to address the key issues that influence deep flexion. Some of the resulting design features apply to both implant designs while others are specific to the cruciate retaining or posterior stabilized knees.

Contact Area and Conformity

Point loading of the femoral component on the tibial bearing can occur with knee prostheses that are not designed for flexion beyond 125 degrees. In time, this loading may damage the polyethylene bearing because the load from the femur is concentrated on a very small area. The edge of the posterior condyles can create “dig in” marks or indentations on the polyethylene surface (Figure 3).

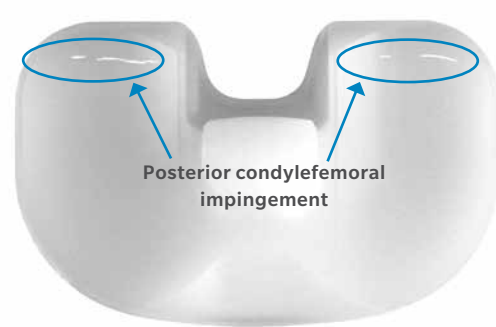

Figure 3

LPS Bearing Component at 155 degrees

This condition was simulated in the laboratory, assuming 155 degrees of flexion under load. An implant system that provides a greater contact area during high flexion can help minimize the possibility of point loading, and thereby reduce the likelihood of “digging” of the metal condyle into the bearing when the knee is flexed beyond 125 degrees. (Figure 4) (Data on file at Zimmer Biomet.)



LPS - Point contact at 155 degrees



LPS-Flex - Conformity at 155 degrees



CR-Flex - Conformity at 155 degrees

Figure 4

The NexGen Flex Knees have addressed this issue with extended posterior femoral condyles. The radius of the posterior femoral condyles has been extended to provide larger tibiofemoral contact area in high flexion (Figure 5). In effect, the conformity between the femoral component and the tibial bearing is enhanced. Increased contact area during flexion of up to 155 degrees helps reduce the possibility of point loading in high flexion. The inside dimension (box cut dimension) of the component requires a flex cut from the posterior condyles. The outside A/P dimension of the component does not change as a result of the flex cut (with the exception of the minus size femoral components for the CR-Flex only).

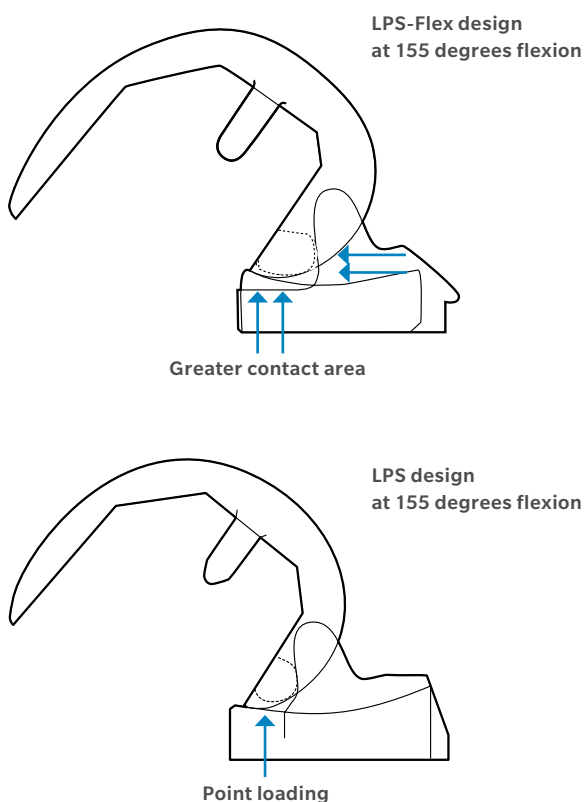

Figure 5

Comparison between the LPS and LPS-Flex at 155 degrees flexion

The radius of curvature in the sagittal plane is important to facilitate the natural rollback of the femur. Constraint and conformity in the NexGen Flex Knees have been optimized to help prevent lift-off and subluxation without restricting kinematics and range of motion. Too much constraint is not desirable for high flexion, as rollback may be compromised.⁶

Stress on the Extensor Mechanism

During deep flexion, the soft tissues of the extensor mechanism are stretched and pulled tightly against the anterior tibia and distal femur. This creates a high level of stress on the patellar tendon, as well as the inferior surface of the patella. Furthermore, because the contact between the patella and femur is more distal and posterior, there is a tendency for the patellar tendon to impinge on the anterior edge of the tibial bearing. An implant system that provides patellar relief on the polyethylene during high flexion can help minimize stress and impingement of the patella tendon extensor mechanism.

To decrease stresses on the quadriceps mechanism during high flexion, material was removed from the anterior face of the bearing component (Figure 6).

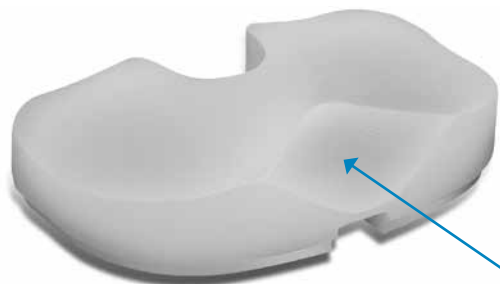

Figure 6

CR-Flex Compatible Bearing with Patella Cut Out

During deep flexion, the patella contacts the femoral component in a more distal and posterior location. More clearance was provided on the bearing to reduce patellar tendon tension, provide relief for the inferior patellar bone, and reduce the potential for patellar tendon impingement (Figure 7). This bearing modification is similar for both the CR-Flex and the LPS-Flex.

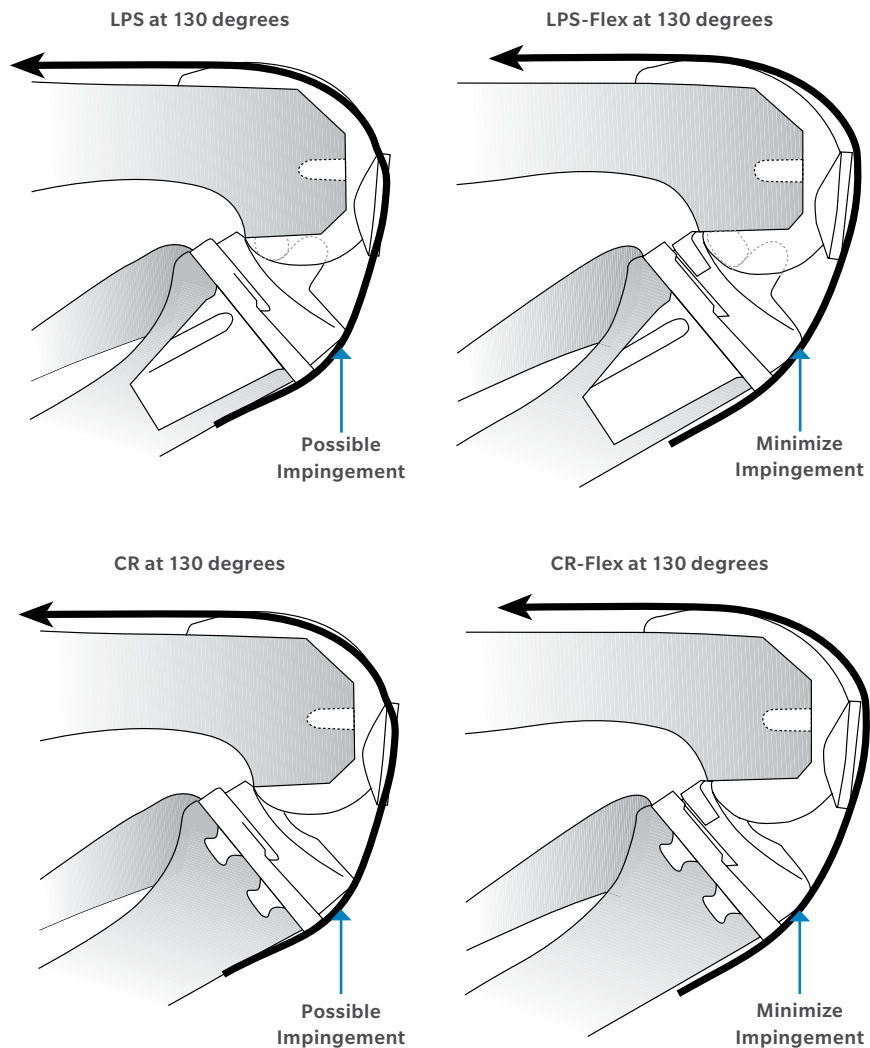

Figure 7

The NexGen Flex Knees have addressed this issue by incorporating a deeper patellar cutout on the anterior face of the tibial bearing component (Figures 8, 9). This provides more clearance to reduce stress on the quadriceps mechanism and help prevent impingement during high flexion.

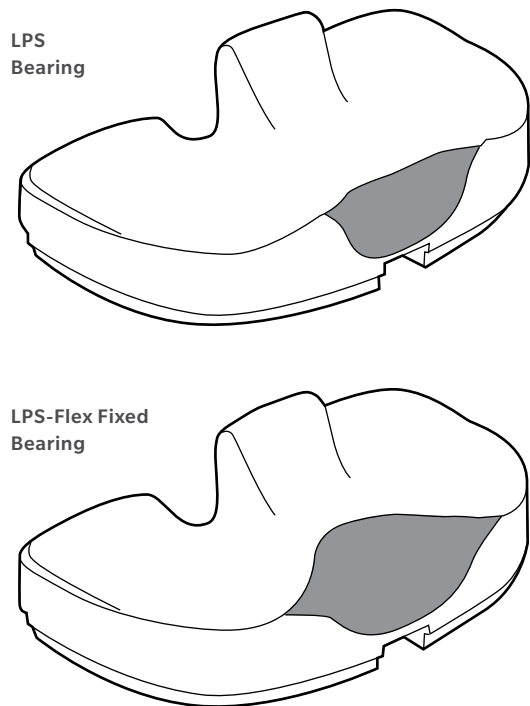

Figure 8

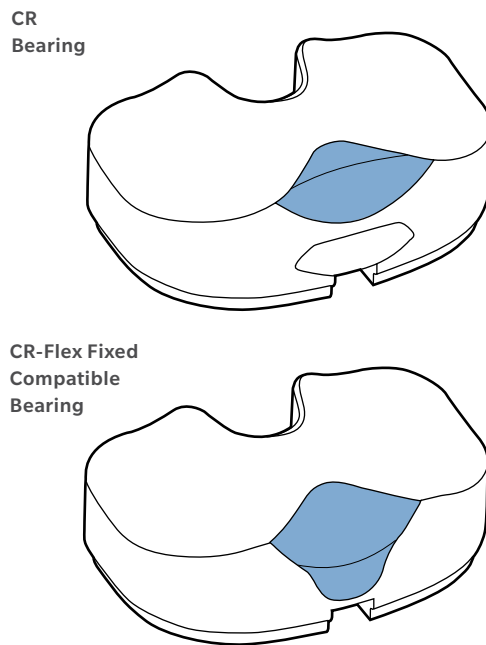

Figure 9

Balancing Flexion and Extension Gaps

Techniques for balancing flexion and extension gaps are variable. Proper gap balancing will maximize stability as the patient performs high flexion activities (Figures 10a, 10b).

The femoral component should be aligned with respect to the epicondylar axis to avoid condylar lift-off and help ensure the best condition for safe, high range of motion.⁹

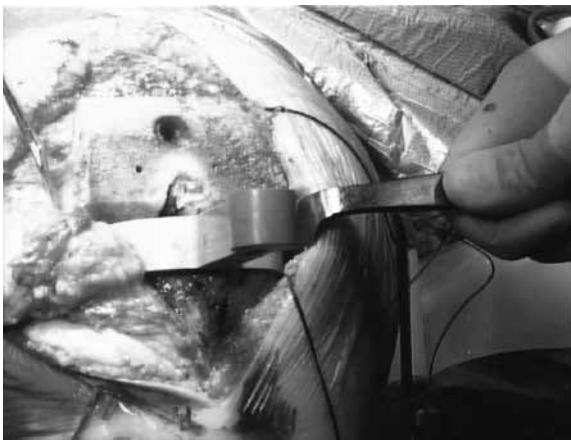

Figure 10a
Flexion Balancing

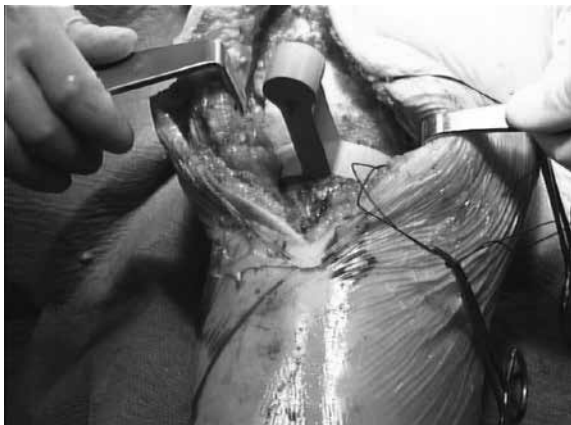

Figure 10b
Extension Balancing

Patellofemoral Design

In designing the NexGen Patellofemoral Articulating Surfaces, significant emphasis was placed on the need to optimize patellar tracking in order to prevent lateral loading tilt, improve overall joint kinematics, minimize the frequency of lateral releases, and reduce deformation. This resulted in deepening, extending, and reorienting the patellar groove within the femoral component, thereby reducing pressure on the patella, achieving anatomic motion from flexion to extension, and maximizing patellofemoral contact area, especially when the patella is under load.

Like all NexGen Femoral Components, the LPS-Flex and CR-Flex Femoral Components have a deep patellar groove that allows the patella to track as deeply, or more deeply than the normal patella.¹⁰ The groove has been extended more distally/posteriorly than on traditional posterior stabilized femoral components, to fully support the patella up to 85 degrees of flexion.

The articulating surface of NexGen Patellas is a modified dome configuration. It is designed to closely match the shape of the patella groove in mid to deep flexion. This optimizes patellofemoral contact area during high load angles of flexion. Also, the rounded lateral ridge increases the resistance to lateral subluxation. The component features a central dome, an angled flat, and a concave radius that correspond to the patellofemoral articulating geometry of the LPS-Flex and CR-Flex femoral components. (For more on the patellofemoral design of the NexGen Legacy PS and NexGen CR please refer to the NexGen Knee Design Rationale.)

Cruciate Retaining

With a cruciate-retaining prosthesis, a number of additional factors are important when attempting to restore function and accommodate deep flexion. These factors include:

Kinematic Differential Rollback

The normal femur does not roll back symmetrically during flexion.¹¹ Because the lateral femoral condyle has a larger sagittal radius than the medial femoral condyle (Figure 11), the femur travels farther on the lateral tibial plateau than on the medial plateau. The primary function of this rollback is to increase the efficiency of the quadriceps extensor mechanism, especially for such flexion activities as stair climbing or gardening.

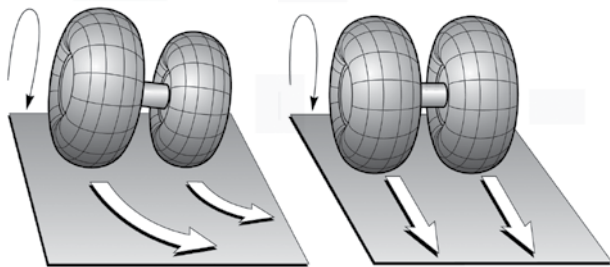

Figure 11

When the knee is flexed from a fully extended position, asymmetric rollback occurs during the first 20 to 30 degrees of flexion, resulting in slight internal rotation of the tibia (Figure 12). This rotation is important in maintaining proper tension in the posterior cruciate and collateral ligaments.

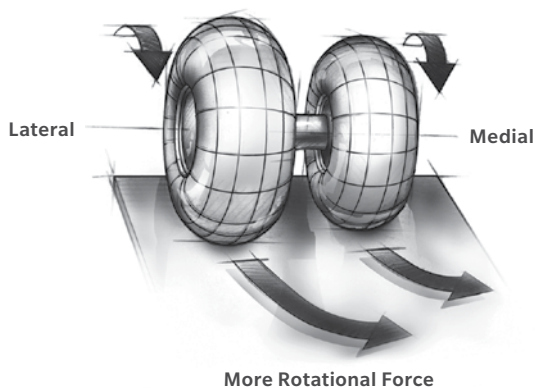

Figure 12

The NexGen Cruciate Retaining Knee Prosthesis is designed to allow for this normal tibiofemoral rotation. In the NexGen CR Femoral Component, the radius of curvature of the lateral distal femoral condyle is larger than that of the medial condyle. These different radii of curvature permit and aid natural posterior rollback, as well as axial rotation of the femur on the tibia, providing optimal stability by working in concert with the soft tissues.

This cruciate retaining prosthesis is designed to mimic the natural rollback of the femur on the tibia.¹² The typical pattern of femoral rollback continues in deep flexion and, therefore, rollback is increased. Two design features have been blended with the CR-Flex:

- On the CR-Flex Fixed Bearing Knee the radius of the lateral condyle has been extended posteriorly to enhance the “Big Wheel/Little Wheel” asymmetric design (Figure 13).
- Extending the posterior condyles aids deep flexion.



Figure 13

Rotational Relief

Rotation between the femoral and tibial components is an important factor in restoring kinematic function. As the femoral component rolls further posteriorly during deep flexion, the larger radius of the lateral condyle increases the amount of external femoral rotation. This may cause the posterior cruciate ligament to impinge on the medial edge of the lateral posterior condyle. The CR-Flex design addresses this issue by reducing the coronal profile of the lateral condyle (Figure 14). Testing indicates that external rotation of the femoral component is increased.

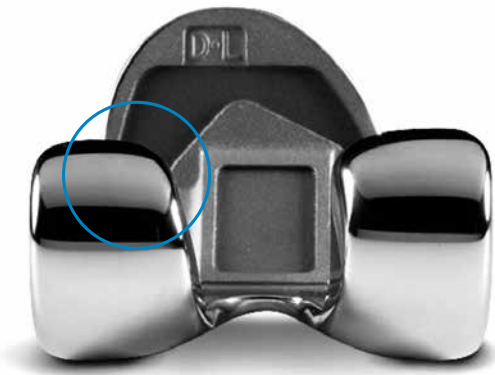

Figure 14

Lateral Retinacular Relief

High-flexion angles may cause additional tension on the lateral retinacular ligament. The CR-Flex design addresses this issue by reducing the height of the lateral posterior condyle relative to the medial posterior condyle (Figure 15). This (1.5 mm) height difference provides relief for the lateral retinacular ligament and may reduce the need for a retinacular release. This reduction in height was intended to mimic the normal anatomic drop in the lateral tibial plateau and the shape of the posterior femoral condyle.^{13,14}

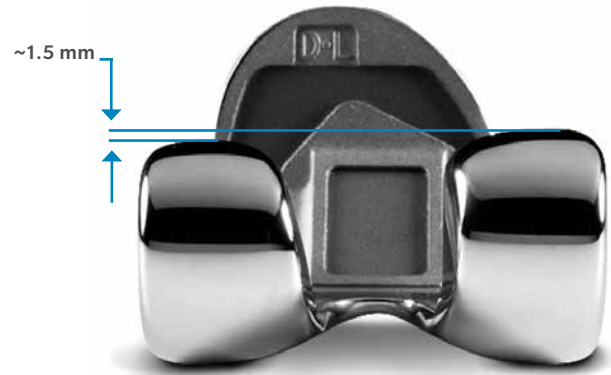

Figure 15

Posterior Stabilized

Design modifications have also been implemented for the posterior stabilized implants to address issues specific to that design. These issues include:

Stability Against Subluxation

In a posterior stabilized design, the cam/spine mechanism provides mechanical rollback while reducing the potential of anterior subluxation of the femur. In some posterior stabilized knees, as the knee goes into deeper flexion, the cam on the femoral component begins to move superiorly on the spine of the tibial bearing. This may increase the possibility of anterior femoral subluxation.

To address this subluxation issue, the shape of the cam on the LPS-Flex femoral component has been modified to contact the spine more inferiorly and thereby provide a greater jump height at flexion angles greater than 130 degrees (Figure 16).

Bending Moment on the Bearing Spine

The proximal movement of the femoral cam on the spine of the tibial bearing may also increase the bending moment applied to the spine. An added benefit of lowering the contact point of the femoral cam on the bearing spine is to reduce the bending moment.

Internal/External Rotation

Research has shown that during high-flexion activities rotation of the tibia of up to 25 degrees can occur.¹⁵ The LPS-Flex knee accommodates the rotation necessary to accomplish these activities by allowing +/-12 degrees of rotational freedom between the femoral component and the tibial bearing.

Fixation

The NexGen Flex Femoral Components use a combination of features designed to provide mediolateral stability and secure fixation. These features include two posts on the distal condyles, a trochlear recess and, on the LPS-Flex component, an intercondylar box. The box cut angles, in conjunction with compression loading, create a wedge effect designed to enhance fixation. These fixation features are similar to those of the NexGen Femoral Components.

Additional test results and design rationale information on the NexGen Femoral, Tibial, and Patellar Components can be found in the NexGen Knee Design Rationale.

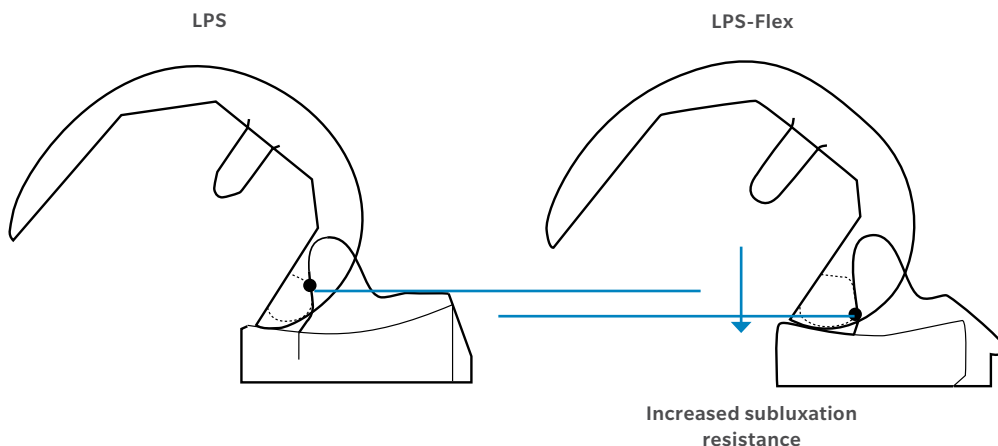

Figure 16
Comparison between the "Jump Height" for LPS and LPS-Flex at 155 degrees of flexion

Instrumentation

The NexGen Flex Knees use the same instrumentation as the standard NexGen Components. One additional instrument has been added to guide the additional resection from the posterior femoral condyles. The box cuts are the same for both the NexGen CR-Flex and NexGen LPS-Flex designs, allowing the surgeon to convert from the cruciate retaining prosthesis to the posterior stabilized prosthesis after the bone has been prepared.

Flex Cut

There are two ways to prepare the femur for the flex femoral component:

1. Posterior Condylar Recut Guide

Due to the extending and thickening of the posterior condyles on the NexGen Flex Femoral Component, an additional posterior condylar cut is necessary and is accomplished with the posterior recut guide (Figure 17).

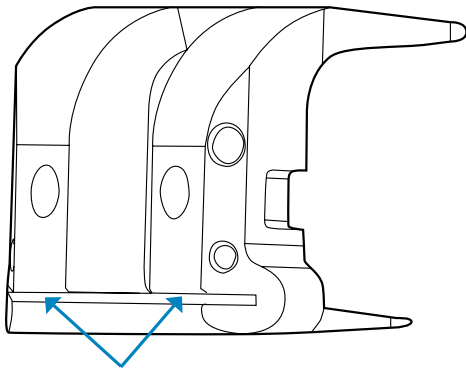

Posterior Recut Guide (size specific)

Figure 17

The posterior recut guides are size specific and are used after the initial femoral bone cuts have been completed with the NexGen Instrument System of choice. The flexion and extension gaps are balanced using the spacer blocks before making the posterior recut. This instrument can also be used to drill the holes for the femoral pegs. A smaller-diameter drill is used for the size A and B LPS-Flex femoral components and size B for the CR-Flex femoral components to match the smaller femoral peg diameter. The smaller femoral pegs help conserve bone between the pegs and the trochlear recess on the smaller sizes.

2. MIS Flex Femoral Finishing Guide

The new Mini-Incision TKA and MIS Quad-Sparing™ TKA Flex Femoral Finishing Guide has incorporated the flex cut into the posterior resection thereby eliminating the need for the posterior recut guide. This instrument follows the 4-in-1 technique (Figure 18).



Figure 18

Testing and Analysis

Functional loads in activities that involve high flexion differ from those activities which require less flexion. The NexGen Flex Knee designs underwent rigorous testing and analysis to verify that they are capable of withstanding these conditions. This testing augmented extensive testing performed during the development of the original NexGen Implants.

NexGen Flex Knee Testing Anterior Lift-off Testing

Testing of the NexGen Bearings in conditions that simulate rising from a chair, walking, and stair climbing show they can withstand the posterior loading that accompanies these activities.^{11,16}

Because the NexGen Flex Bearings are designed for high-flexion activities, the additional potential for anterior lift-off and disassociation of the bearing from the tibial base plate must be considered. In addition to the magnitude of the applied load, the load position and direction may also influence lift-off.

The required load capacity for the NexGen Flex Knees was determined experimentally by Andriacchi¹⁷⁻¹⁸, in combination with X-ray analysis. It was determined that the peak tilting moment force is approximately 1.4 times body weight during a squatting activity with a peak flexion angle of 155 degrees (Figure 19).¹⁴

To verify the effectiveness of the fixation mechanism during high-flexion, for both thin and thick tibial bearings were tested to simulate anterior lift-off loading conditions. As a result of this testing, the 17 mm and thicker bearings require a secondary locking mechanism. The test duration was 225,000 cycles, representing 20 years of service for a patient who performs an average of 30 squatting activities per day.

The tibial component assemblies withstood the loading requirements without loss of function of the assemblies during this experiment. There were no impending failures or indications of damage at the conclusion of the tests. (Data on file at Zimmer Biomet.)

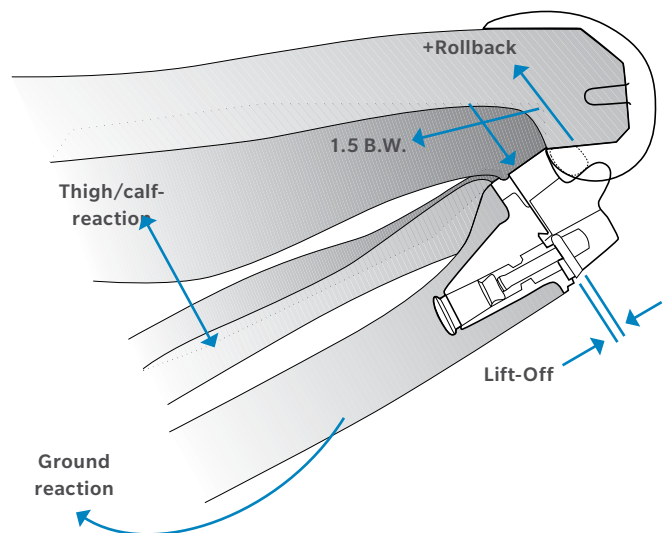

Figure 19

LPS-Flex Testing for Anterior Surface Lift-Off (225,000 Cycles)

Contact Area and Conformity

The design goal was to maximize contact area during high flexion (155 degrees). By extending the posterior femoral condyles, greater contact area at high-flexion angles is achieved. This increased contact area minimizes point contact stresses during high flexion up to 155 degrees.

From Tech Memo 1294.02: The results show no statistical difference in contact area for the CR-Flex at 0, 10, 45, and 90 degrees when compared to the CR knee design (both conventional and Prolong

Polyethylene materials). The CR design showed significantly higher contact area at 130 degrees and the CR-Flex design showed significantly higher contact area at 155 degrees (Figure 20). (Data on file at Zimmer Biomet.)

Note: This test was performed on both the CR Prolong™ Highly Crosslinked Polyethylene and conventional polyethylene.

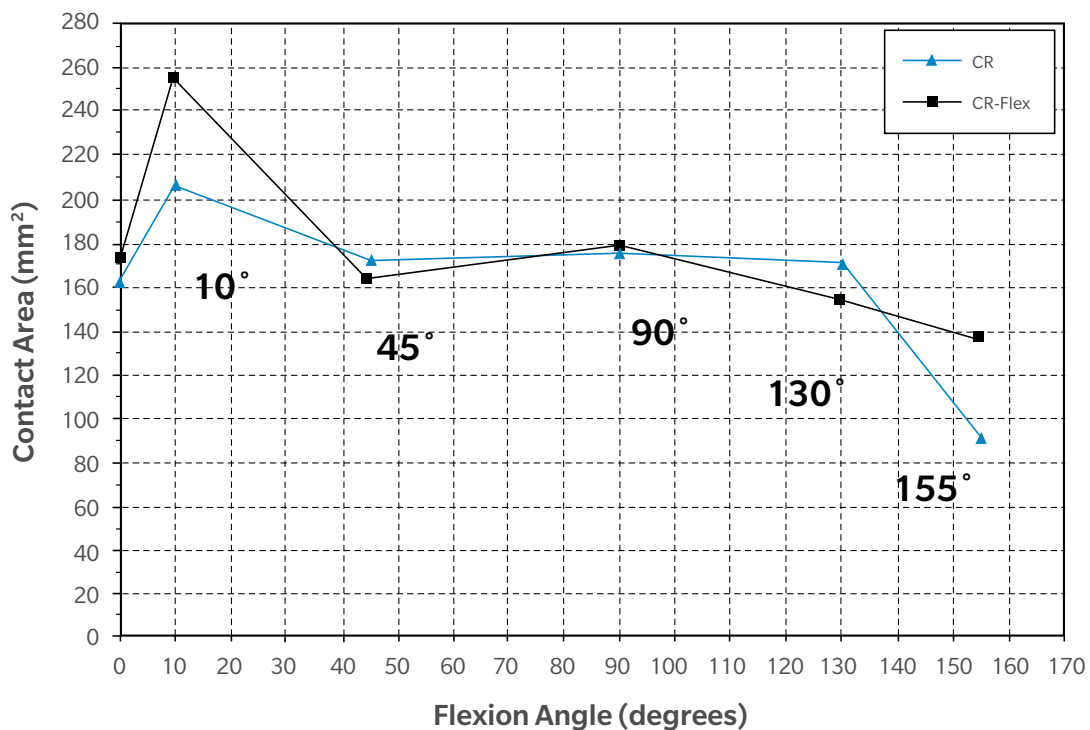

Figure 20
NexGen CR vs. NexGen CR-Flex

Because of the design modifications of the LPS-Flex, which extend the femoral posterior condyles, greater contact area between 120 and 155 degrees is achieved (Figure 21). This increased contact area minimizes point contact stresses during high flexion up to 155 degrees. Improvements in the contact area and conformity are also seen at the walking gait cycle due to minor modifications made at the sagittal radii of the LPS-Flex femoral and bearing components.

This contact area was measured experimentally using Tekscan Sensor Technology. This technique provides the needed accuracy, repeatability, and ease of use (data on file). Size D was used for the study and a load of 3200N was applied. The chart below represents the contact area from 0 to 155 degrees flexion range. The data shows that at 155 degrees flexion the contact area is close to 200 mm² (data on file). The higher contact area is attributed to the extension of the posterior condyles as described earlier.

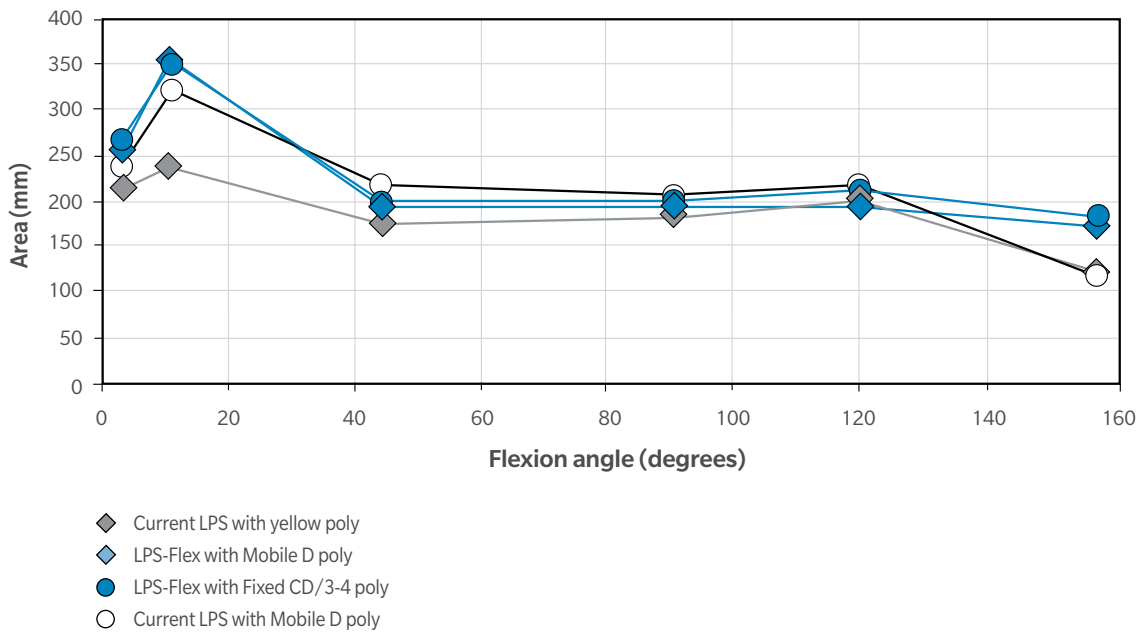

Figure 21
Comparison of Contact Area

Secondary Locking Mechanism

The CR-Flex and LPS-Flex fixed bearings utilize the same bearing to plate, double dovetail locking mechanism as used in the current NexGen LPS Knee. The 17 mm and thicker fixed bearing articulating surfaces also require a secondary locking mechanism that consists of a taper stem plug or stem extension and locking screw (Figure 22). This locking mechanism is similar to the current LCCK locking mechanism. The taper plug provides the necessary engagement for the locking screw. A stem extension can also be used in place of a taper plug.

The screw is packaged with the 17 mm and thicker bearing. The screw used in the fixed bearing is plate size specific and thus not interchangeable. The existing LCCK torque wrench is used to tighten the locking screw to 95 in-lbs. A built-in tibial holding rack, which is part of the sterilization case, can be used to hold the tibial tray while the locking screw is being tightened using a back table technique. The option of assembling the locking screw intraoperatively using an LCCK tibial plate wrench is also available. The 14 mm and thinner bearing thicknesses do not require this secondary locking mechanism.

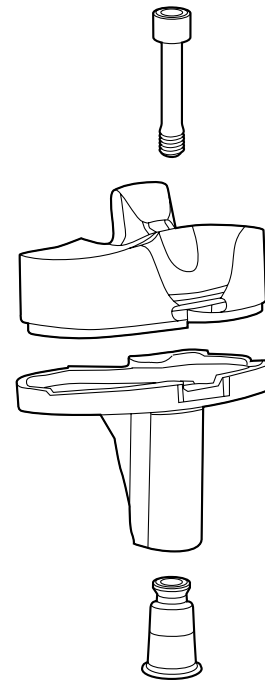

Figure 22

Assembly of the 17 or Thicker LPS-Flex Fixed Surface

NexGen CR-Flex Testing

Posterior Edge Loading

This test studied whether the minimum thickness of the tibial bearing would survive the anticipated high-flexion activities for a lifetime of 20 years. The study simulated high-flexion loading that includes extreme posterior edge loading and internal tibial rotation.

In the setup, the femoral component was flexed to 155 degrees with simulated 7 degree tibial slope as described in the current surgical technique. The femoral component at 155 degrees flexion was positioned on the posterior edge of the tibial bearing.^{9,19} The occurrence of these extreme conditions is understood to be less often than normal walking gait conditions. The test duration was 219,000 cycles, representing 20 years of service for a patient who performs an average of 30 squatting activities per day.

The results demonstrated no visible cracks or indications of surface damage following the loading. Additionally, ultrasonic inspection yielded no evidence of cracks in any of the test specimens (Figure 23). (Data on file at Zimmer Biomet.)



Figure 23
Posterior Edge Loading Testing Apparatus

Note: This test was performed on both CR Prolong and conventional polyethylene.

Femoral Component Strength Analysis

The objective of this analysis was to verify that the minus size CR-Flex femoral component could withstand loading of the condyles. Comparison was made to the CR components, which have a known clinically excellent history.²⁰ They have also been successfully tested under conditions simulating extreme posterior loading in walking gait.²¹

Finite Element Analysis (FEA) was used to determine the stress on the femoral condyles. The peak tensile stress of each condyle was determined for a given load set, i.e., loads representing a particular flexion angle. The chart below demonstrates the relationship between flexion angles and maximum stress (Figure 24).

The analysis reveals that the stresses are comparable between the CR and CR-Flex designs; thus, the CR-Flex design can be expected to exhibit excellent endurance performance comparable to the NexGen CR Knee without any greater risk of breakage. (Data on file at Zimmer Biomet.)

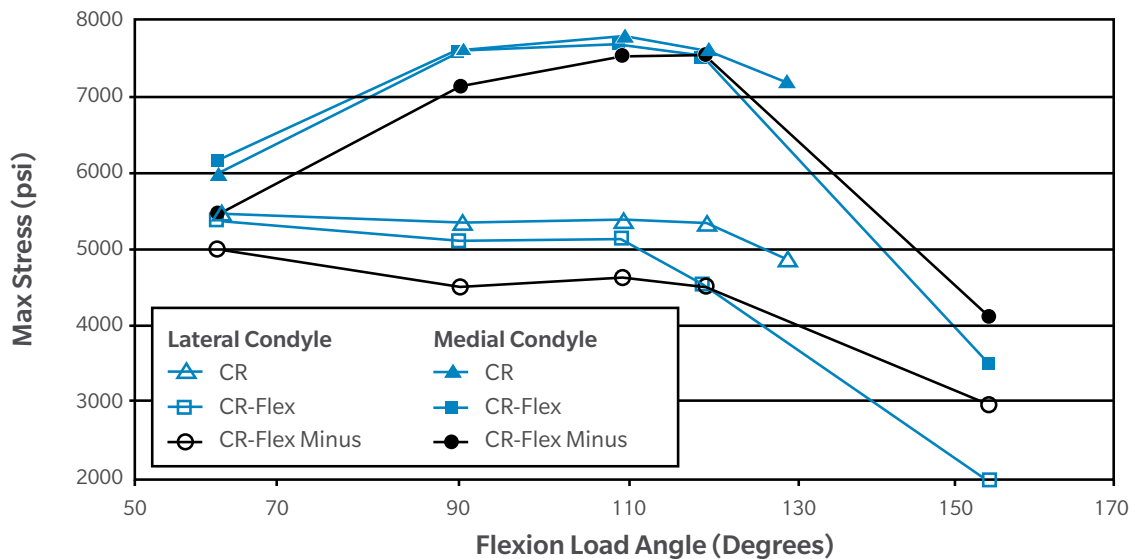

Figure 24

Patellofemoral Joint Compression Analysis

An analysis was performed to estimate the patellofemoral joint compression force for high-flexion squatting, in comparison to other high-load activities with more usual flexion ranges, such as ascending or descending stairs, or rising from a chair.

The compression force for these activities was determined based on a patellofemoral joint model by Nisell²⁰ using external joint loads from Andriacchi for the squatting and the stair conditions, and from Kelley for the chair-rise condition.^{22,23} The model also takes into account the soft tissue load-sharing effects. Although in squatting, the overall joint loads are generally greater than during the other activities, the actual increases for the compressive patellar forces are relatively small as the additional load is borne by the more proximal quadriceps tendon. As flexion progresses beyond the 90 to 120 degree range, the patella begins to lose contact with the distal condyles while the engagement of the quadriceps tendon increases around the trochlear surfaces (Figures 25, 26).

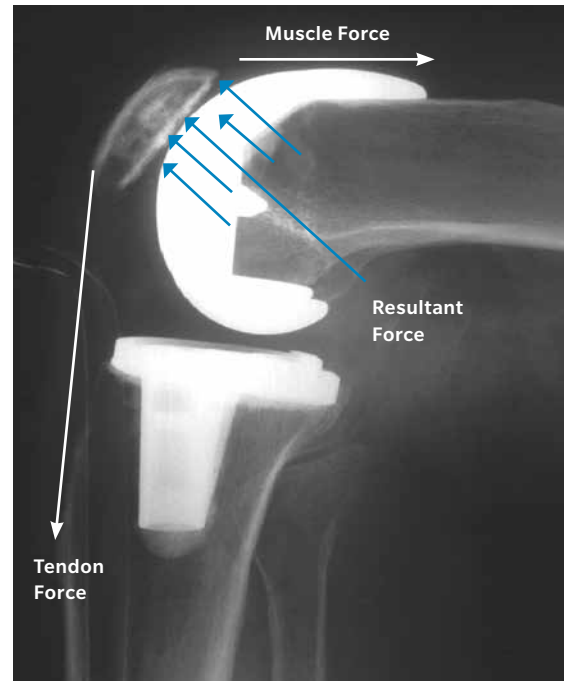

Figure 25

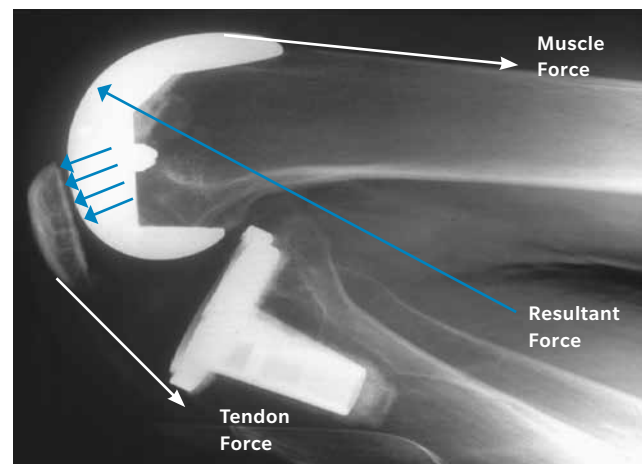

Figure 26

The estimated peaks and corresponding flexion angles were recorded for each activity (Figure 27). The joint compression for squatting was found to peak at around 4.2 times body weight (B.W.) and is within the magnitudes estimated for stair ascent and descent, and chair rise. In addition, this peak was found to occur at the peak flexion angle of 155 degrees. Because the patella begins to lose contact with the femoral condyles, it is not fully supported past 85 degrees of flexion. Therefore, the peak loading on the patella during squatting will occur with reduced support in comparison to the two stair activities. However, the chair-rise analysis estimated that its peak loading, which exceeded that of squatting, occurs at 110 degrees with the patella also not fully supported. This analysis is applicable for both CR-Flex and LPS-Flex.

In summary, the patellofemoral joint loading conditions anticipated for squatting are within those experienced by current designs during other conditions such as stair ascent and descent, and chair rise.

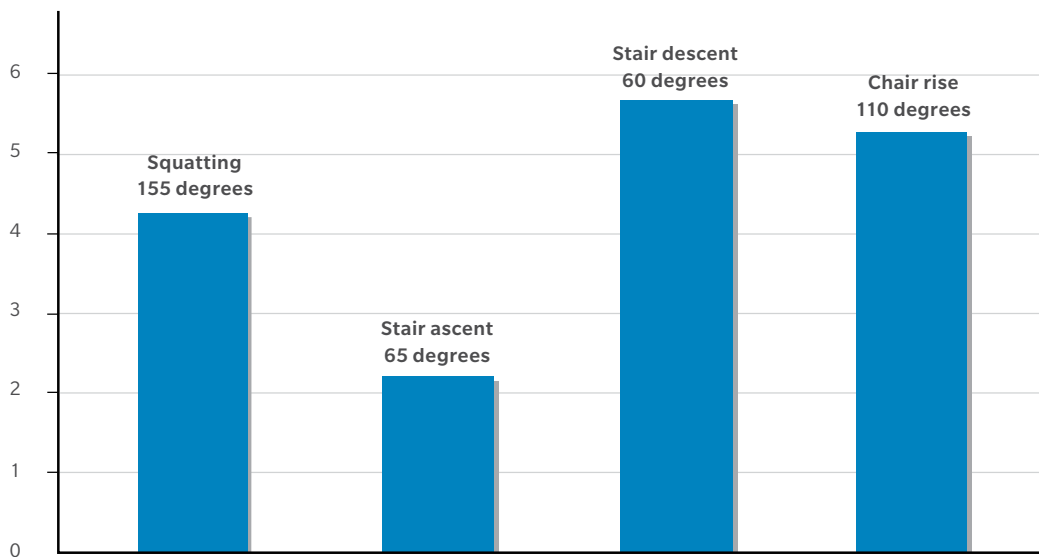

Figure 27

Comparison of Patellofemoral Joint Compression Loads by Activity

Nexgen LPS-Flex Testing

Bearing Spine Testing

During activities that involve high flexion, such as squatting, the force acting on the spine of the bearing from the femoral cam could be higher than in more usual activities such as stair ascent or descent. This is because the body is placed further posteriorly at higher flexion angles in relation to the knee joint center, resulting in increased flexion moments on the joint.

In order to accommodate this condition, one of the key objectives in the design of the LPS-Flex tibial bearing was to lower the cam/spine contact point so that it remains near the base of the spine in high-flexion angles. This helps ensure that the spine bending moment arm does not increase in extreme flexion and minimizes the effects of the increased spine forces.

Using external joint loads predicted by Andriacchi in combination with X-ray analysis, it was determined that the most extreme condition would occur during squatting, with a spine force reaching up to two times body weight at the peak flexion angle of 155 degrees (Figure 28).^{24,25} Since the spine load will also be transmitted through the bearing to the tibial base plate component, the testing was carried out on component assemblies. This included both thin and thick bearings in order to include verification of the strength of the secondary screw fixation used on the 17 mm and thicker components. The test loads were cyclically applied for 225,000 cycles, which is roughly equivalent to more than 30 squatting cycles per day for 20 years.

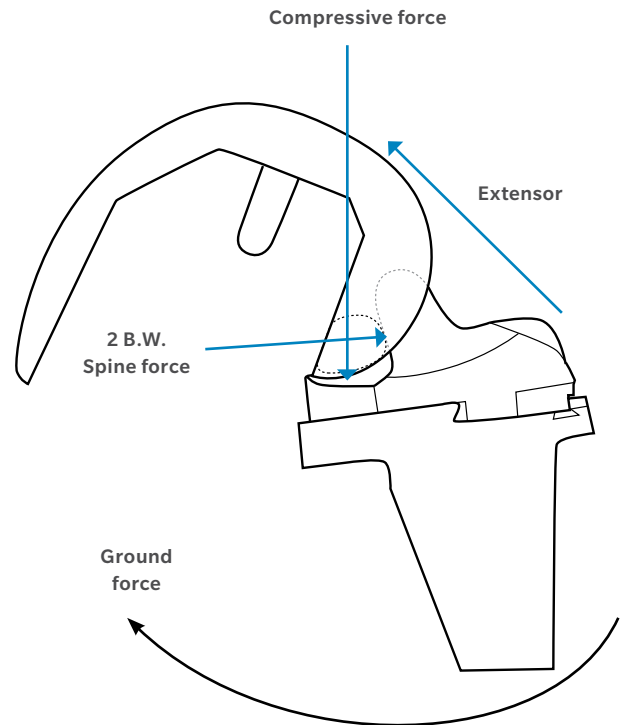

Figure 28
LPS-Flex Testing for Spine Strength (225,000 cycles)

All components completed the tests without breakage of the spines or failure of the bearing locking mechanisms, including the auxiliary screw.²⁶ The results indicate that the spine design of the LPS-Flex tibial bearing, as well as the locking mechanism designs, are capable of withstanding the extreme conditions of high-flexion activities as estimated by the loading models.

Posterior Lift-Off Testing

Tests were also performed to verify the design of the LPS-Flex components under conditions that tend to lift the bearing posteriorly. The most extreme condition in which this effect may occur is in a patient who shifts weight to one knee, while in the kneeling position, to facilitate getting up from the floor. In certain cases, depending on how much the load-bearing knee is extended prior to rising and how far forward the patient's center of gravity is positioned, the force on the bearing spine from the femoral cam can exceed the tibiofemoral compression. This will tend to lift the bearing posteriorly and could potentially cause its disassociation from the tibial base-plate, with the effect being most pronounced on the thicker components.

Based on a biomechanical analysis of the activity, the worst case conditions were found at around 95 degrees of flexion with a 0.9 x B.W. spine force and a 0.5 x B.W. tibiofemoral compression force (Figure 29).²⁷ These conditions were applied in the

tests to both thick and thin component assemblies to verify the integrity of both the screw augmented fixation as well as the primary fixation. The loads were cyclically repeated for 50,000 cycles, which is roughly equivalent to seven occurrences of these conditions per day for 20 years.

For the LPS-Flex (Fixed) design, the fixation was found to be insensitive to these loading conditions as would be anticipated based on the successful clinical long-term performance of the NexGen double dovetail fixation, which was adopted in the LPS-Flex (Fixed) design. For the LPS-Flex mobile components, only the thicker components (17 and 20 mm) showed some posterior lifting effects (data on file). These lifting effects on the thicker components were safely resisted by the secondary screw on these components.

In summary, the test results indicate that the fixation designs of the LPS-Flex bearings are effective in resisting posterior lift-off conditions as simulated in laboratory conditions.

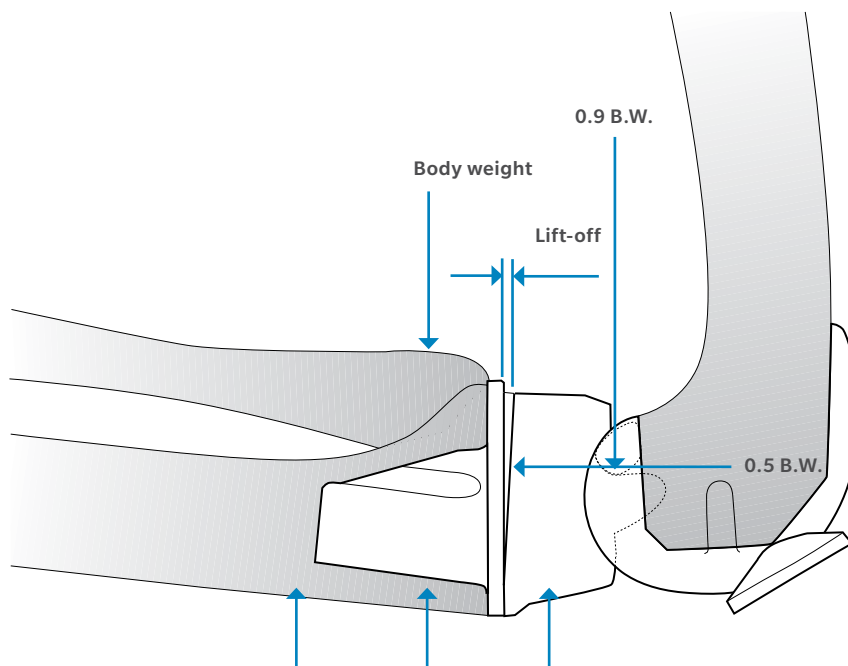

Figure 29

LPS-Flex testing for posterior lift-off (50,000 cycles)(Test done on both the mobile and fixed bearing system)

References

1. Shojl, H. *et al.* Factors Affecting Postoperative Flexion in Total Knee Arthroplasty. *Orthopedics*. 13(6): 643–49, 1990.
2. Kim, J. *et al.* Squatting Following Total Knee Arthroplasty. *Clinical Orthopaedics and Related Research*. (313): 177–86, 1995.
3. Harvey, I. *et al.* Factors Affecting the Range of Movement of Total Knee Arthroplasty. *Journal of Bone and Joint Surgery*. 75-B(6): 950–55, 1993.
4. NexGen Knee 7-year clinical results.
5. Junnosuke, R. *et al.* Factors Influencing the Postoperative Range of Motion in Total Knee Arthroplasty. *Bulletin: Hospital for Joint Diseases*. 52(3): 35–40, 1993.
6. Insall, J. Current Knee Implant Designs Lack Sufficient Flexion for Certain Cultures. *Orthopedics Today*. 17, 1999.
7. Komistek, R. Correlation Between Condylar Lift-Off and Malrotation of the Femoral Component: A Report by the Rocky Mountain Musculoskeletal Research Laboratory, 1999.
8. Niwa, S. Hyperflexion in Japanese Knee Replacement Design and Clinical Results: Developments and Problems in Total Knee Arthroplasty. The Wellington Knee Surgery Unit's 8th International Teaching Meeting, London, England. 51–62, 1998.
9. NexGen Knee Design Rationale, Zimmer Publication: Patient Specificity. 1999;(4):4.1–4.11.
10. *Ibid.* Ref. 10, LPS-Flex Design Rationale.
11. Insall, J. *Surgery of the Knee*. NY: NY: Churchill Livingstone. 9, 1984.
12. Bertin, K. *et al.* In Vivo Determination of Posterior Femoral Rollback for Subjects Having a NexGen Posterior Cruciate-Retaining Total Knee Arthroplasty. *The Journal of Arthroplasty*. 17.8: 1040–48, 2002.
13. Urabe, K. *et al.* Comparison Between the Shape of Resected Femoral Sections and Femoral Prosthesis Used in Total Knee. *Journal of Knee Surgery*. 16.1: 27–33, 2003.
14. Andriacchi, T. Personal communication on features of knee anatomy to enable high flexion. 2001.
15. Niwa, S. Ref. 9 from LPS-Flex Design Rationale. Hyperflexion in Japanese Knee Replacement Design and Clinical Results: Development and Problems in Total Knee Arthroplasty. The Wellington Knee Surgery Unit's 8th International Teaching Meeting, London, England. 51–62, 1998.
16. Belleman, J. *et al.* Fluoroscopic Analysis of the Kinematics of Deep Flexion in Total Knee Arthroplasty: Influence of Posterior Condylar Offset. *Journal of Bone and Joint Surgery*. 84-B(1): 50–53, 2002.
17. Andriacchi & Nagura. Report to Zimmer: Evaluation of Dynamic Forces During Kneeling.
18. Dahlkvist, N. *et al.* Forces During Squatting and Rising from a Deep Squat. *Eng. Med*. 11(2): 69–76, 1982.
19. Most, E. *et al.* Abstract: Tibiofemoral Contact for Conventional and High-Flexion Posterior Cruciate-Retaining Total Knee Arthroplasty Designs.
20. Andriacchi, T. Personal communication on joint loads as measured during hyper-flexion squatting. 1998.
21. Ref. 10 from Posterior Edge Loading.
22. Andriacchi TP, Andersson GBJ, Fermier RW, *et al.* A study of lower-limb mechanics during stair-climbing. *J Bone Joint Surg*. 1980;62-A(5):749-757.
23. Ref. 11 from Posterior Edge Loading.
24. Andriacchi, T. *et al.* A Study of Lower-Limb Mechanics During Stair-Climbing. *Journal of Bone and Joint Surgery*. 62-A(5): 749–57, 1980.
25. Ref. 5 from Posterior Edge Loading.
26. Ref. 1 from FEA.
27. Ref. 4 from Posterior Edge Loading.

For more information contact your Zimmer Biomet representative or visit us online at zimmerbiomet.com.

©2016 Zimmer Biomet



ZIMMER BIOMET

Your progress. Our promise.™



Legal Manufacturer

Zimmer, Inc
1800 West Center Street
Warsaw, IN 46581-0708
USA